

MELGES²⁰

REICHEL PUGH
YACHT DESIGN

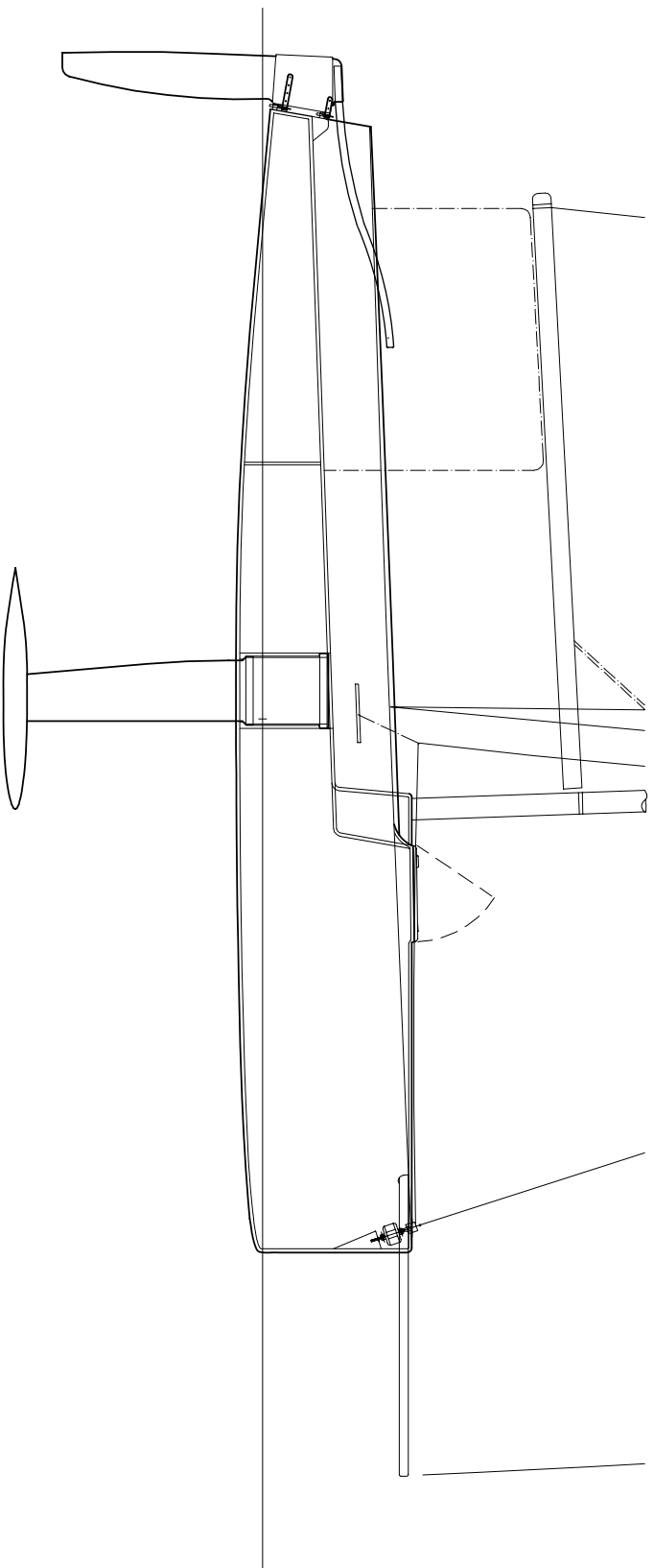
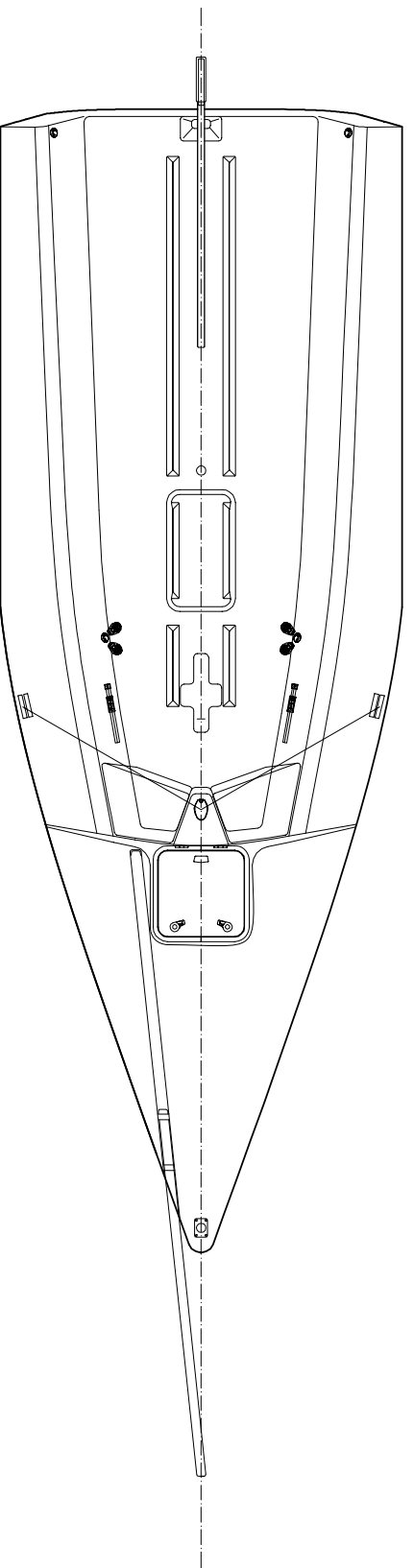

MELGES 20

REICHEL PUGH
YACHT DESIGN

Design Features

- A modern Melges look
- Smooth comfortable design throughout with large radius edges
- Large comfortable cockpit with simple to sail deck layout
- No winches!
- Enclosed interior with access while sailing
- High freeboard for a dry ride
- Flat stable aft planing hull sections
- Fine bow entry for upwind performance
- Carbon fiber "M" rig setup for the ultimate performance, simple to tune
- Above boom vang system
- Carbon fiber bowsprit
- Retractable high aspect keel with weed cutter
- Retractable high aspect rudder system
- Square top mainsail design for ultimate performance and modern appearance
- Roller furling zipper luff jib with battens
- Permanent forestay
- Mast head asymmetrical spinnaker with retrieval line
- Custom trailing package that is easy to tow behind any vehicle
- Easy to rig, launch and retrieve from a boat ramp
- Easy to launch from a hoist with a single point lift
- Main sheet bridle system
- No backstay
- Legs in with restricted hiking
- Large foot rests on cockpit floor
- Motor well in deck for motor stowage and easy access
- Open class sailing, all sailors welcome
- Emphasis on youth and female participation
- No crew weight rule
- Open to all sailmakers
- Two boat in a container on trailers
- Four boats in a container stacked
- Race ready from the factory!
A just add water approach – the Melges Way!
- Gottifredi Maffioli line package with every Melges 20!
- No fairing – a strict one design!